

TENDER FORM FOR THE SUPPLY OF INFRASTRUCTURE SYSTEM (to be completed in duplicate)

Name and Address of School : Islamic Kasim Tuet Memorial College
22 Tsui Wan Street, Chai Wan, Hong Kong.

School Reference No. : IKTMC21/22-Infrastructure-01

Tender Closing Date and Time: 12:00 noon, Feb 28, 2022

PART I : Contents of Tender

| Particulars | Quantity * | Unit Amount (HKD) |
|-------------------------------------|------------|-------------------|
| Infrastructure whole network design | 1* | |
| a) Core Switch | 1 | |
| b) Access Switch 48 port | 4 | |
| c) Access Switch 24 port | 4 | |
| d) Optical Fiber cabling | 8 | |
| e) Cat 6 cables w/ PVC conduit | 221* | |
| f) Rack mount cabinet | 8* | |
| g) Accessories & cabling | 14* | |
| h) Helpdesk service | 1 | |
| j) Maintenance and warranty 3 years | 1 | |
| k) others | 1 | |

*The exact number is yet to be confirmed

PART II : Declaration of suppliers

The undersigned hereby offers to supply all or any part of the items described in the tender schedule attached with the delivery term quoted therein against the date of a firm order placed by the school at the price or the prices quoted in the tender schedule free of all other charges and in accordance with any drawings and/or specifications provided by the school. In so doing, the undersigned acknowledges that all items not otherwise specified shall be in accordance with British Standard specifications where such exist; tenders shall **REMAIN OPEN FOR 90 DAYS** after the Closing Date; and the school is not bound to accept the lowest or any tender and reserves the right to accept all or any part of any tender within the period during which the tenders remain open. The undersigned also warrants that his Company's Business Registration and Employees' Compensation Insurance Policy are currently in force and that the items which his Company offers to supply do not to his knowledge infringe any patents.

PART III : Prevention of Bribery Ordinance

- I. The bidder, its employees and agents shall not offer any advantage (as defined in the Prevention of Bribery Ordinance, Cap. 201) to the school employees, SMC/IMC members, or any parent or student representative in a committee responsible for considering any matters in relation to this contract. Any such offer by the bidder or its employees or agent may constitute an offence under the Prevention of Bribery Ordinance and may render the contract null and void. The school may also cancel the contract awarded and hold the bidder liable for any loss or damage the school may sustain.

II. If a school employee or supplier or contractor has committed any of the above offenses, the tender will not be considered and the contract signed will be invalidated even if it has come into effect.

PART IV :

Duly authorized to sign tenders for and on behalf of :-

whose registered office is situated at _____

_____ Hong Kong.

Business Registration Certificate No. : _____ (Expiry date : _____)

Telephone No. : _____

Fax No. : _____

Signature : _____

Company Chop : _____ Name of Person In Charge : _____

Date : _____ Title of Person In Charge : _____
(State official position, e.g. Director, Manager, Secretary, etc.)

Appendix A

1F Network Map

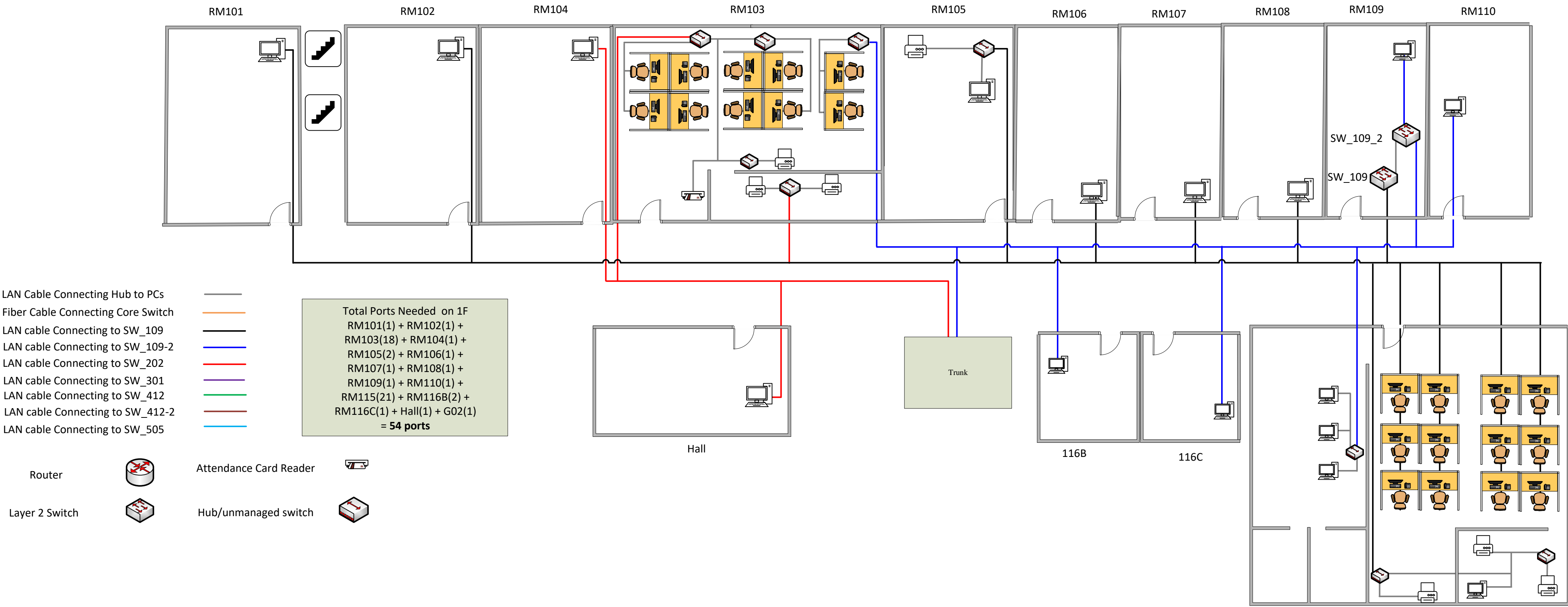

2F Network Map

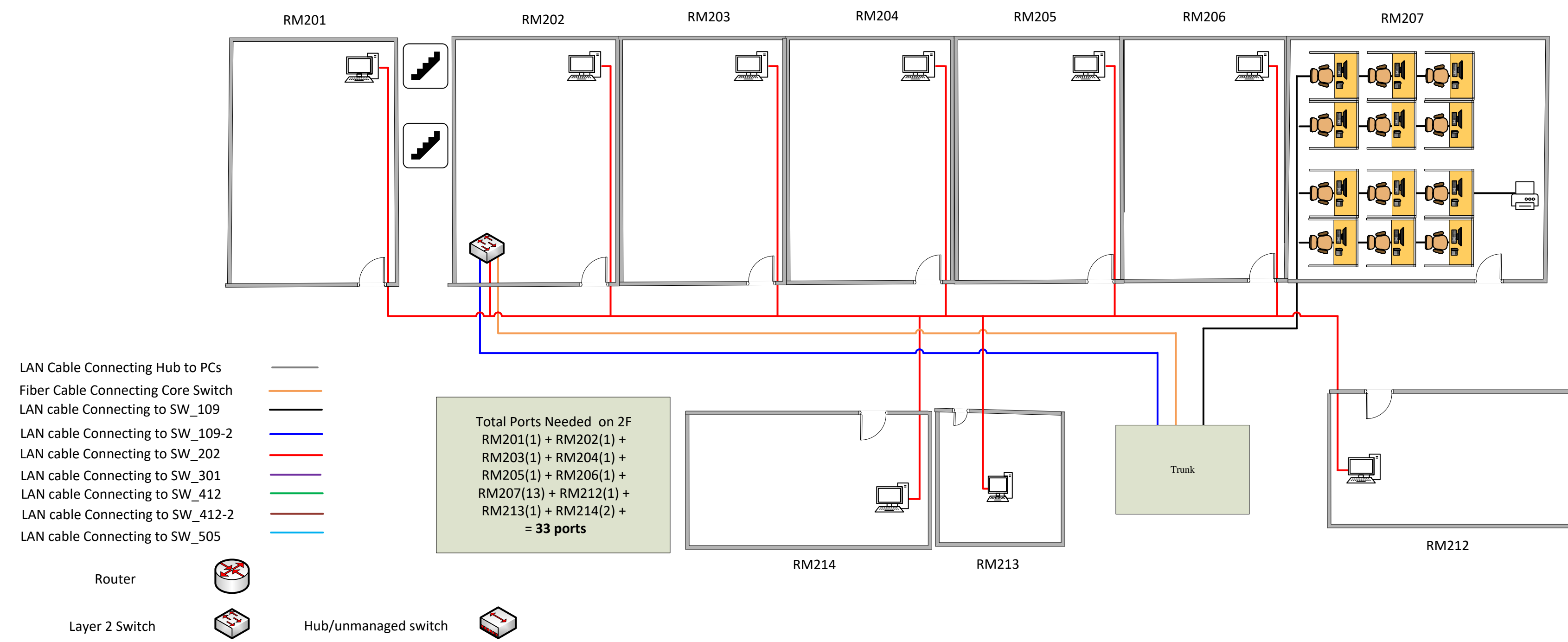

3F Network Map

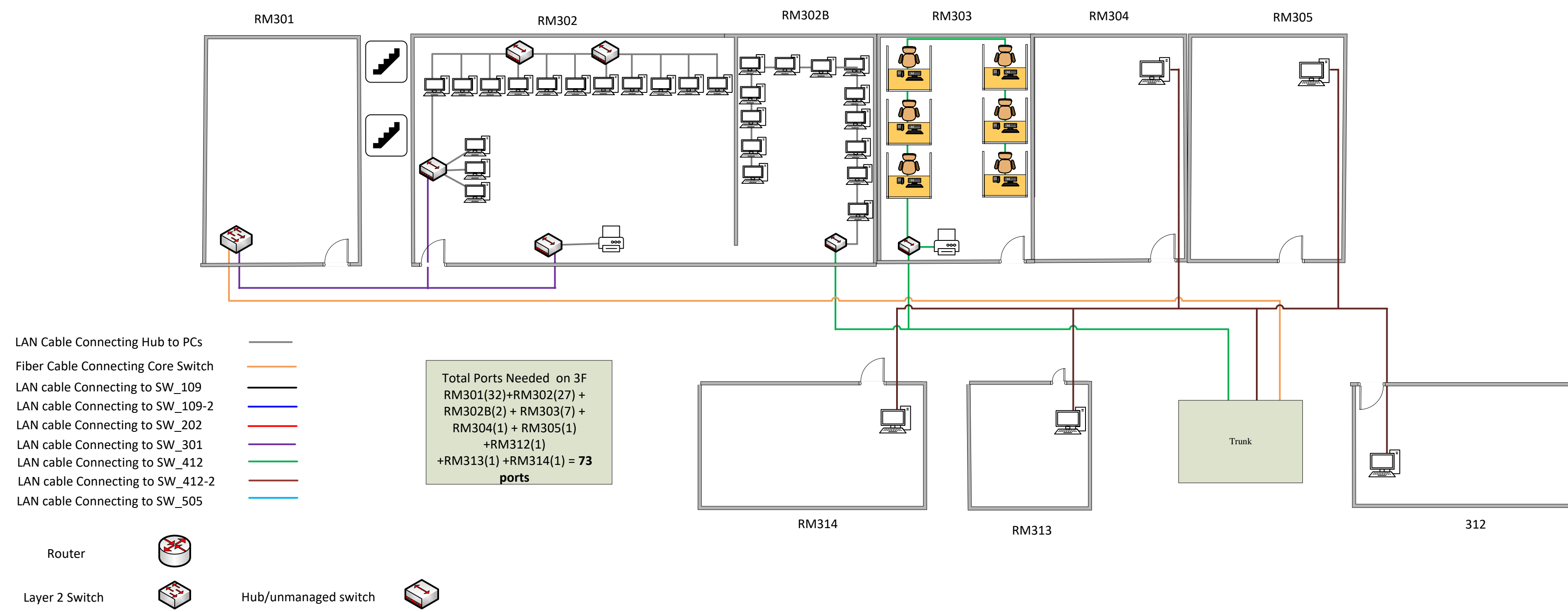

4F Network Map

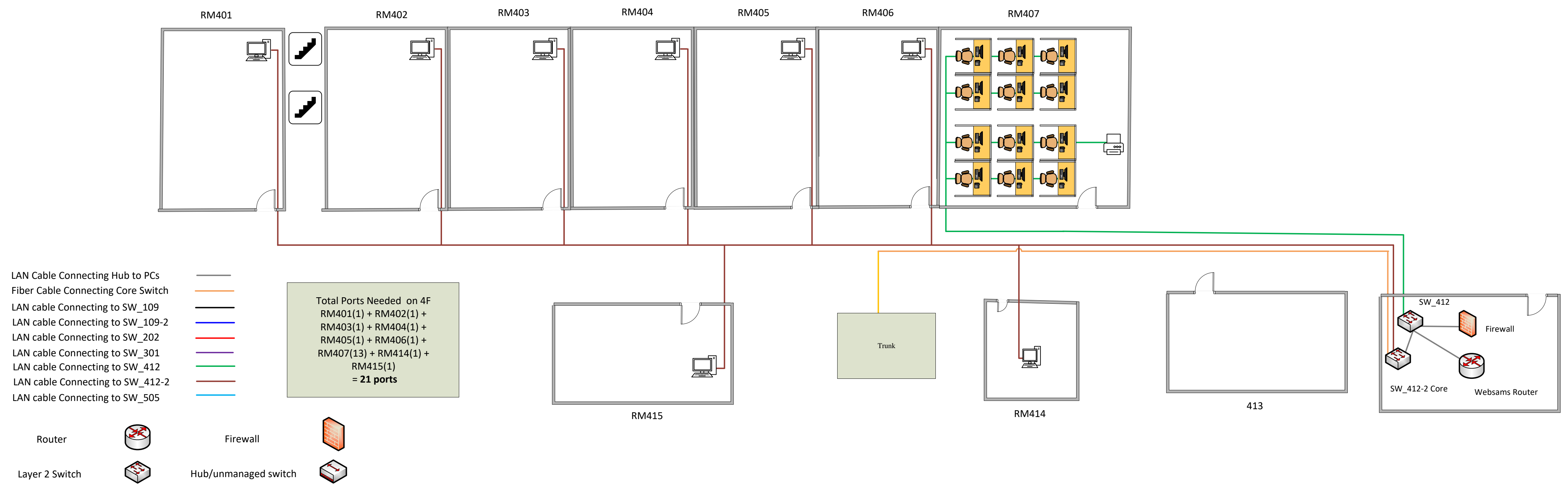

5F Network Map

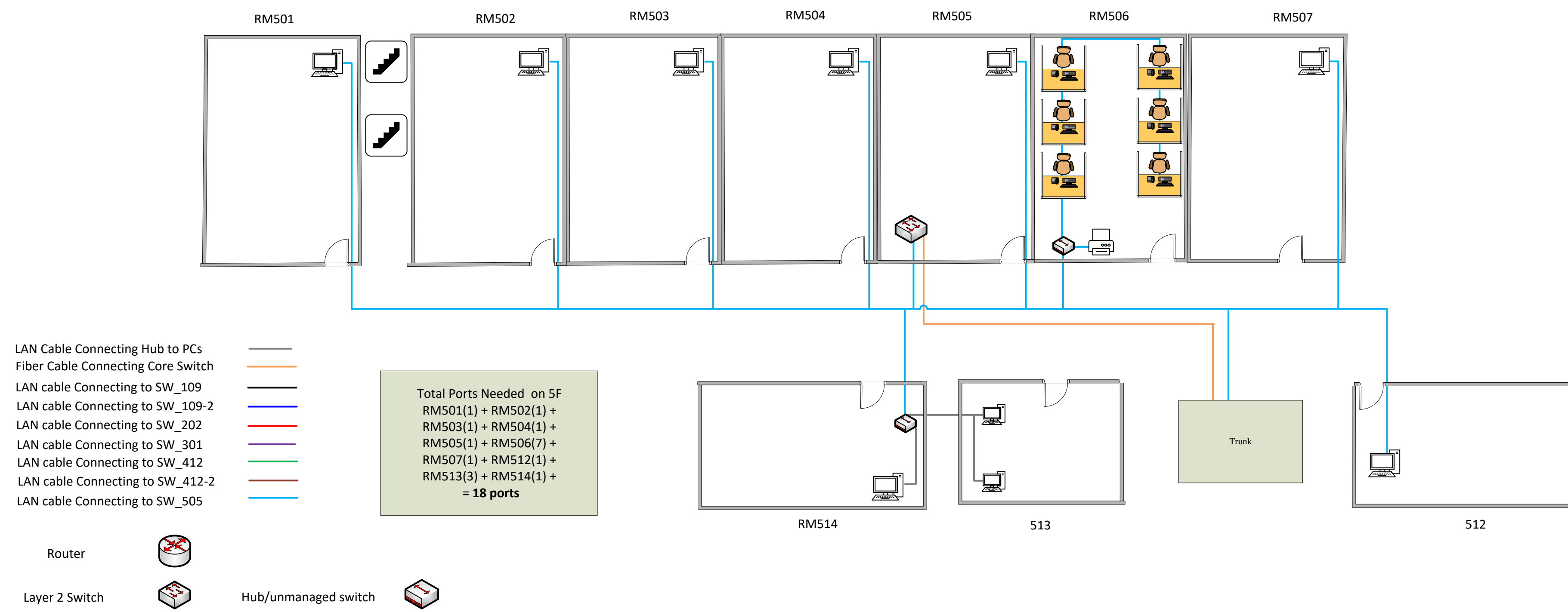

6F Network Map

